

**NATURAL STONE PAVING AND SOFT LANDSCAPE INTERFACE**

1  
2500

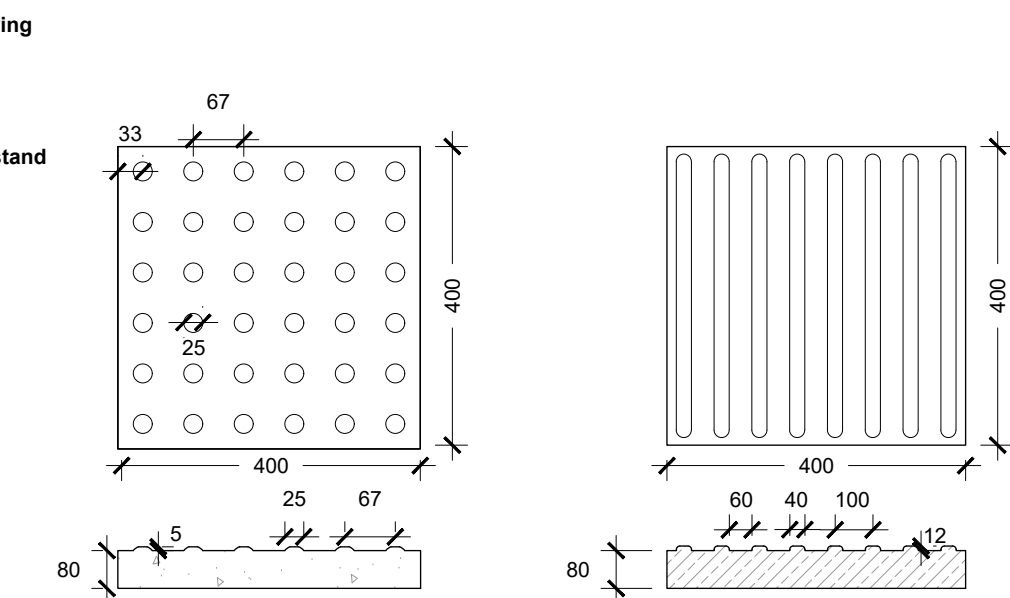

**NATURAL STONE TACTILE PAVING**  
scale 1:10

2  
2500

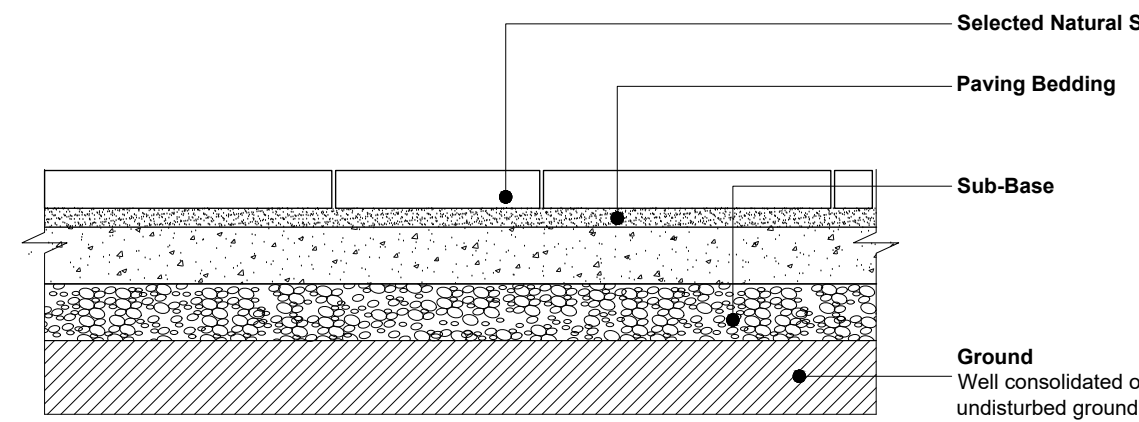

**NATURAL STONE PAVING SELECTED LARGE FORMAT**

3  
2500

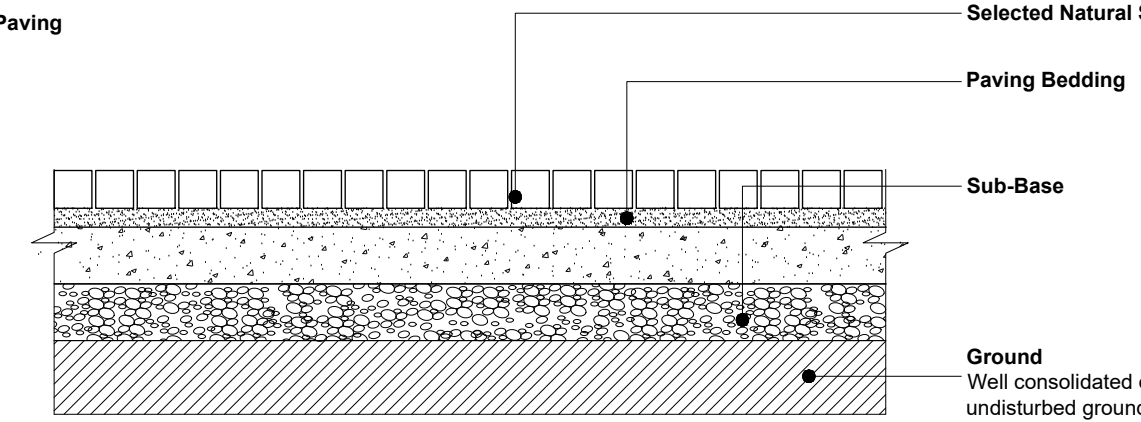

**NATURAL STONE PAVING SELECTED SMALL FORMAT**

4  
2500

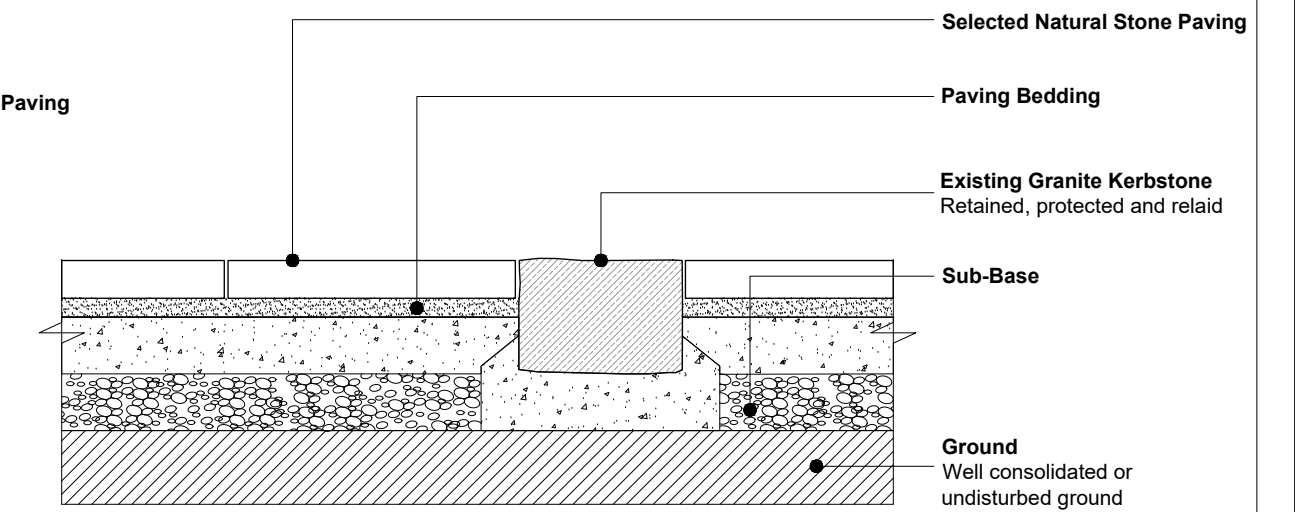

**NATURAL STONE PAVING AND EXISTING GRANITE KERB INTERFACE**

5  
2500

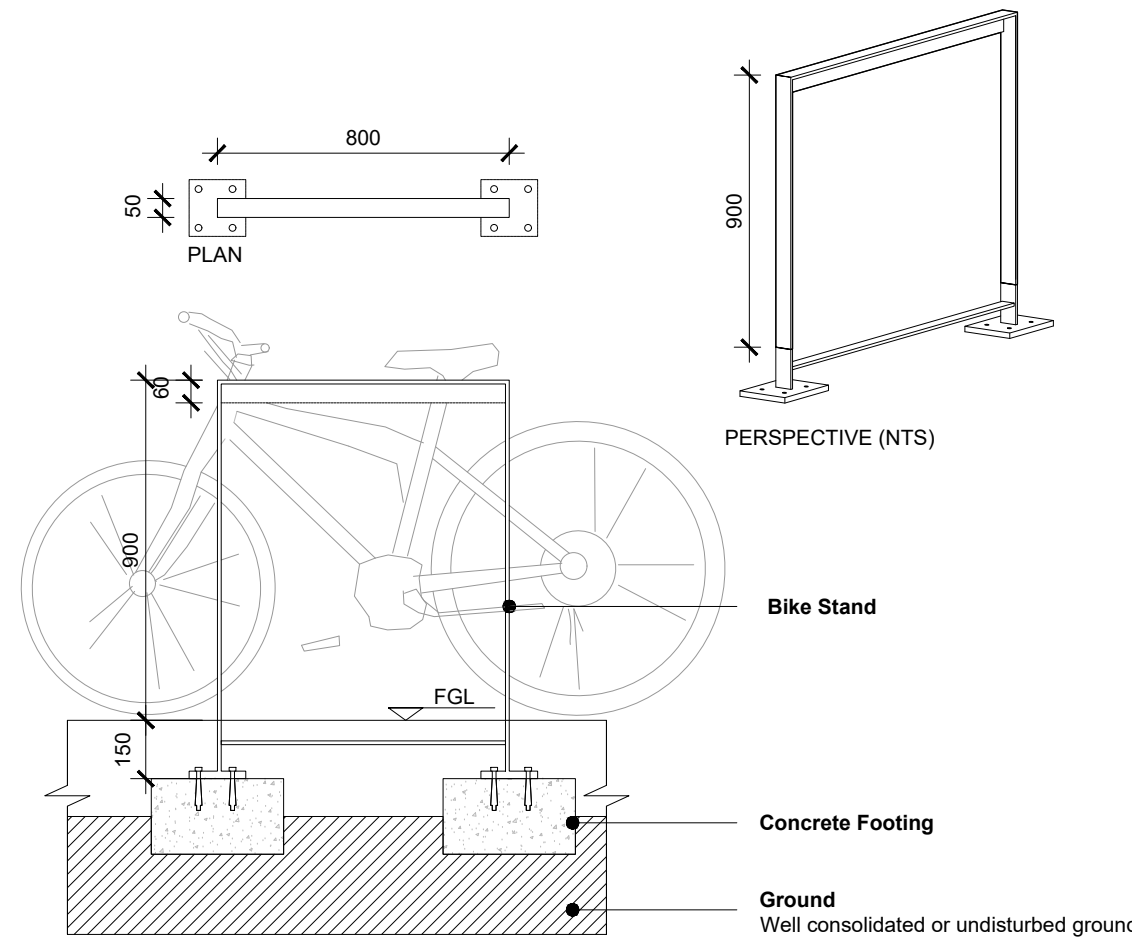

**BIKE STAND**

6  
2500

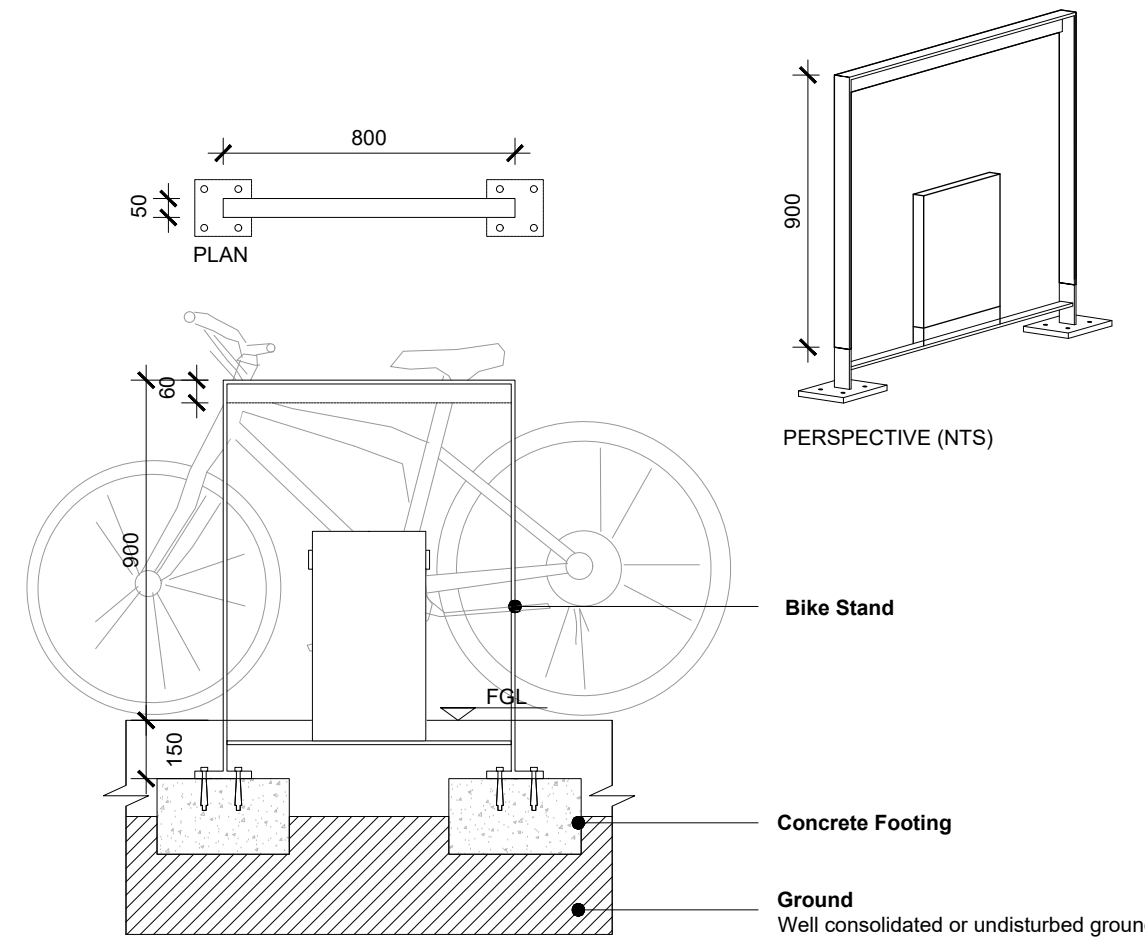

**ELECTRIC BIKE STAND**

7  
2500

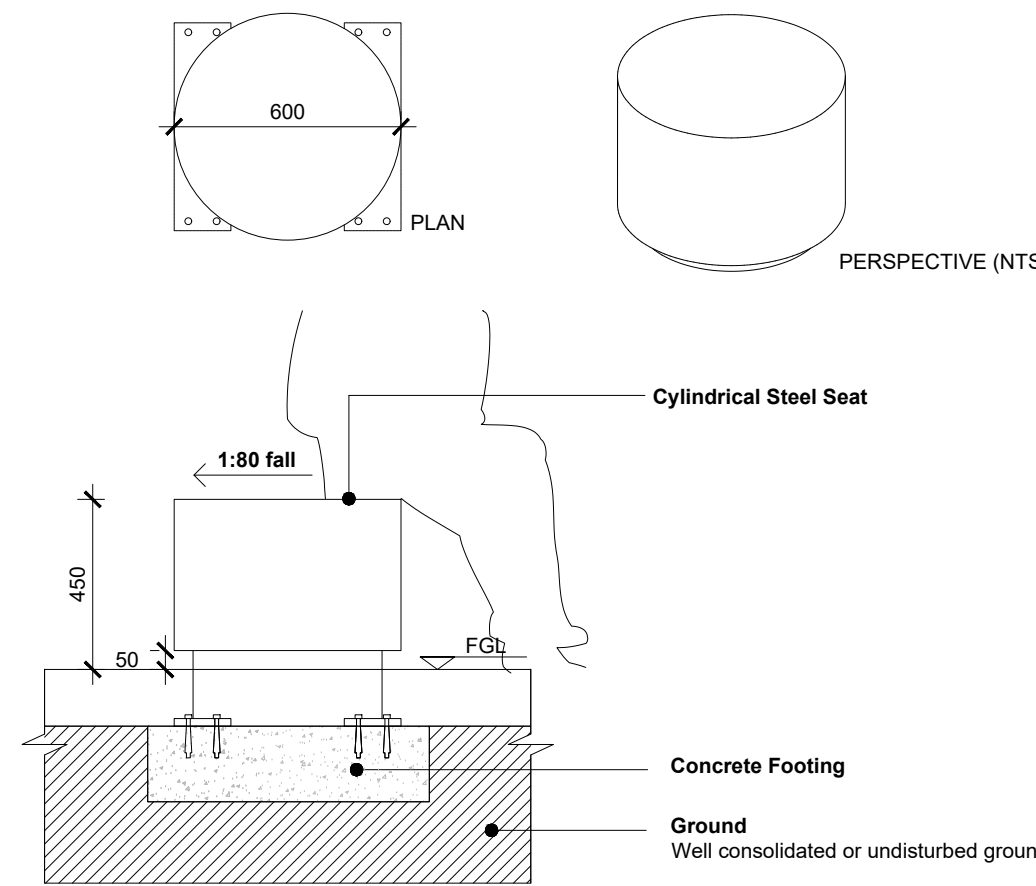

**CYLINDRICAL SEAT**

8  
2500

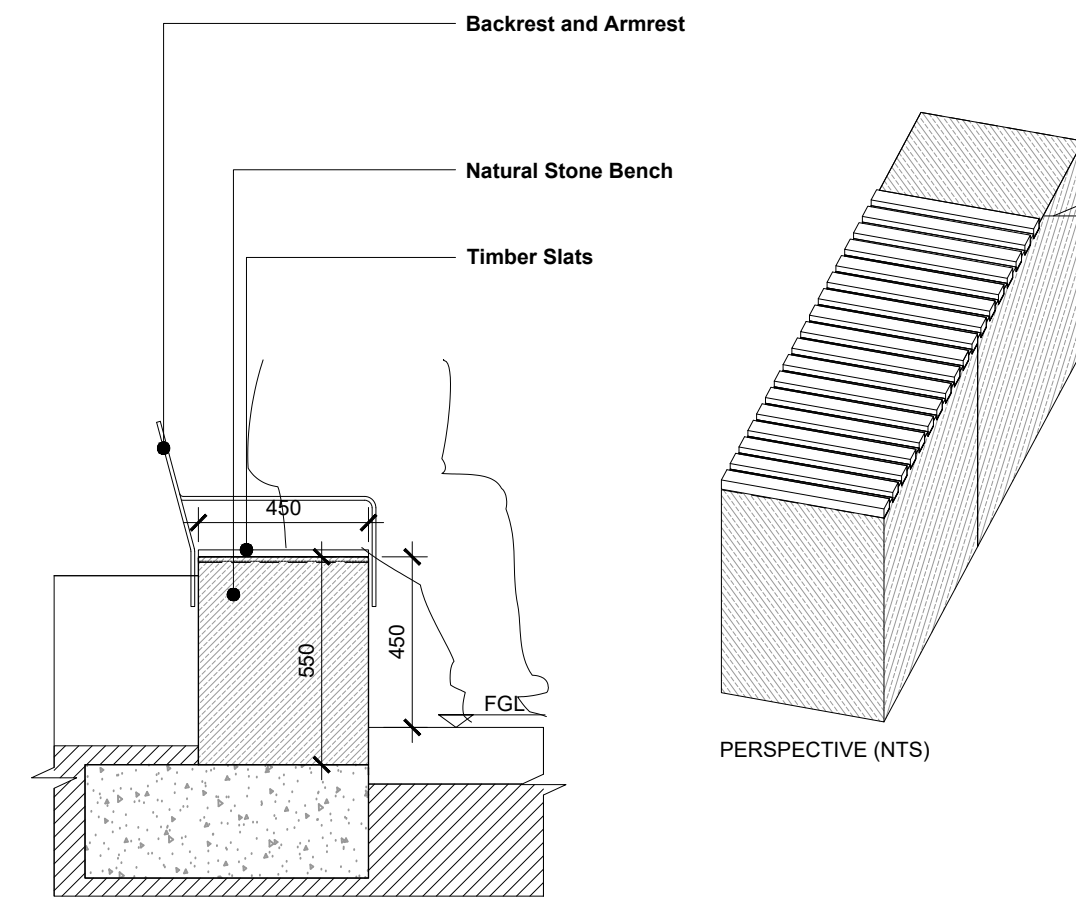

**NATURAL STONE BENCH**

9  
2500

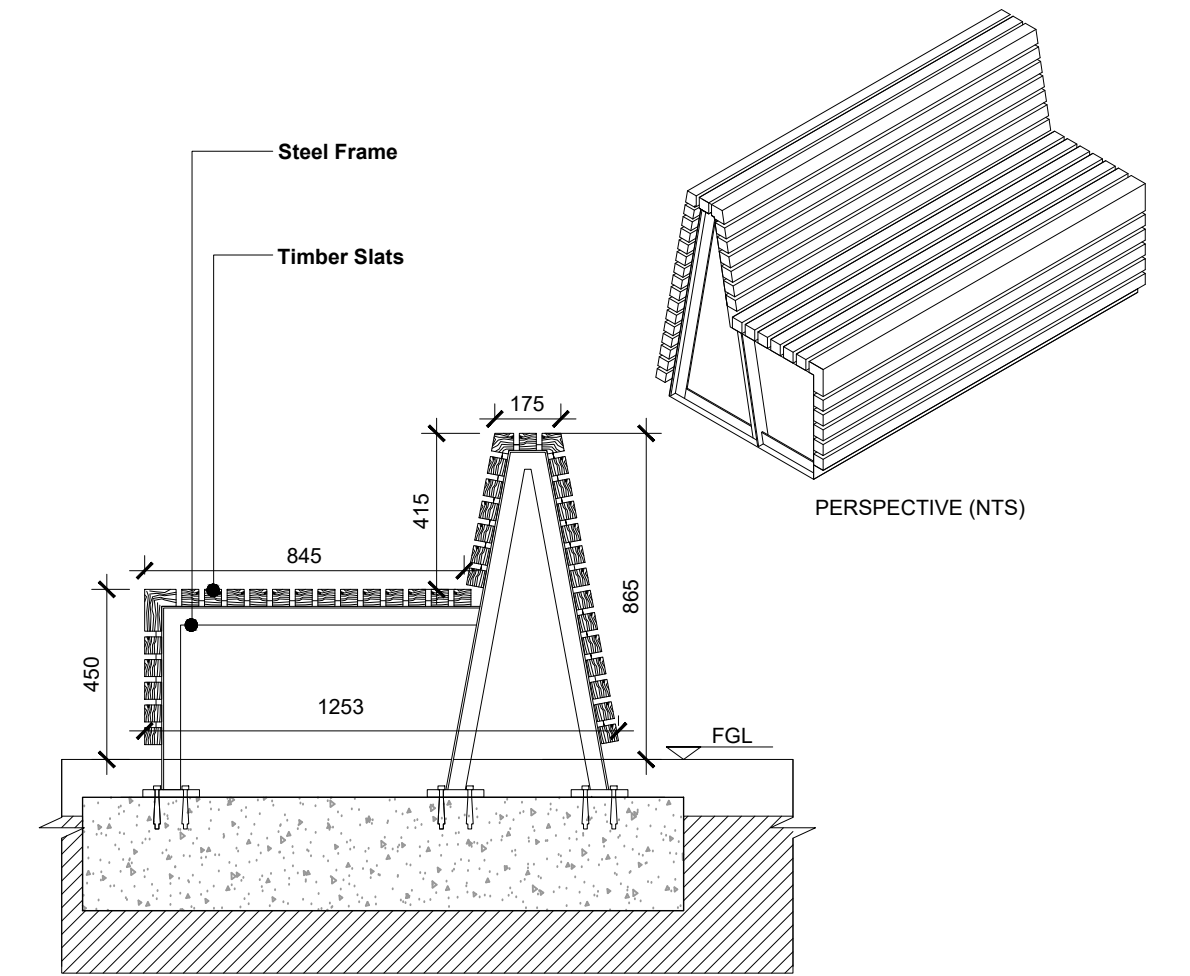

**TIMBER BENCH**

10  
2500

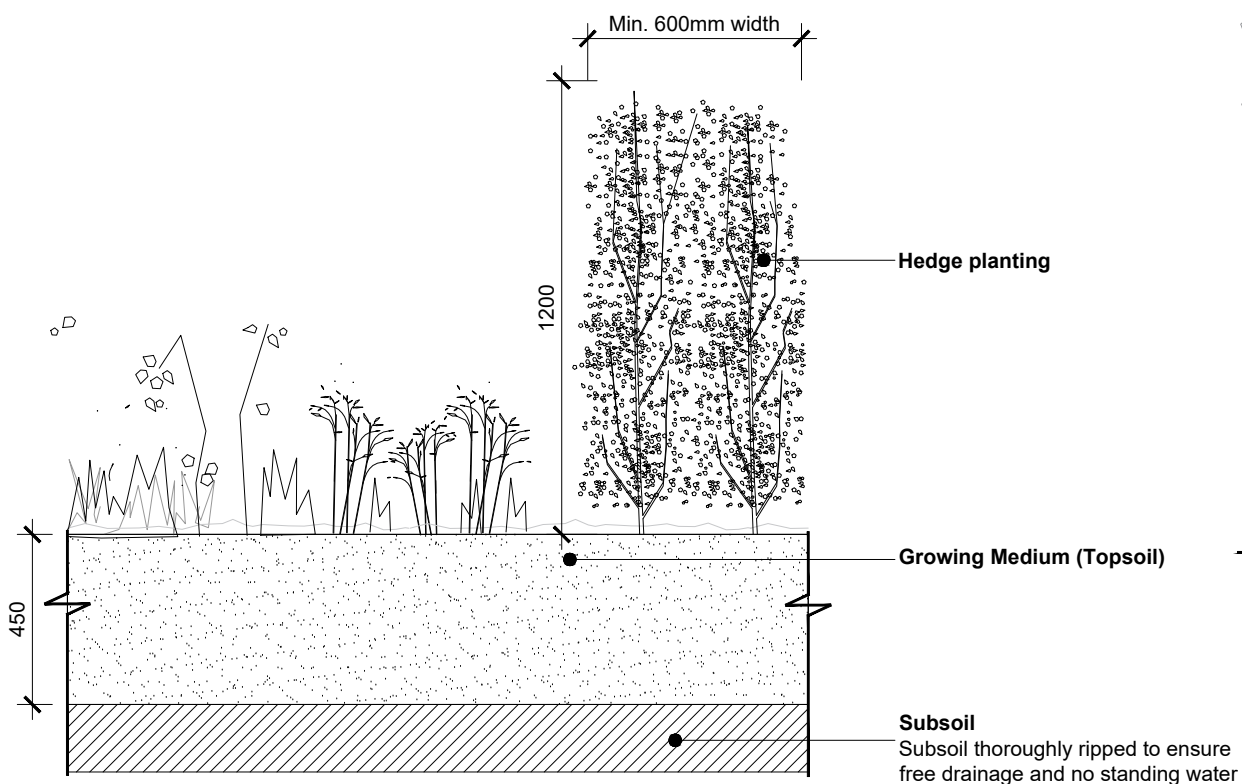

**PLANTING**

11  
2500

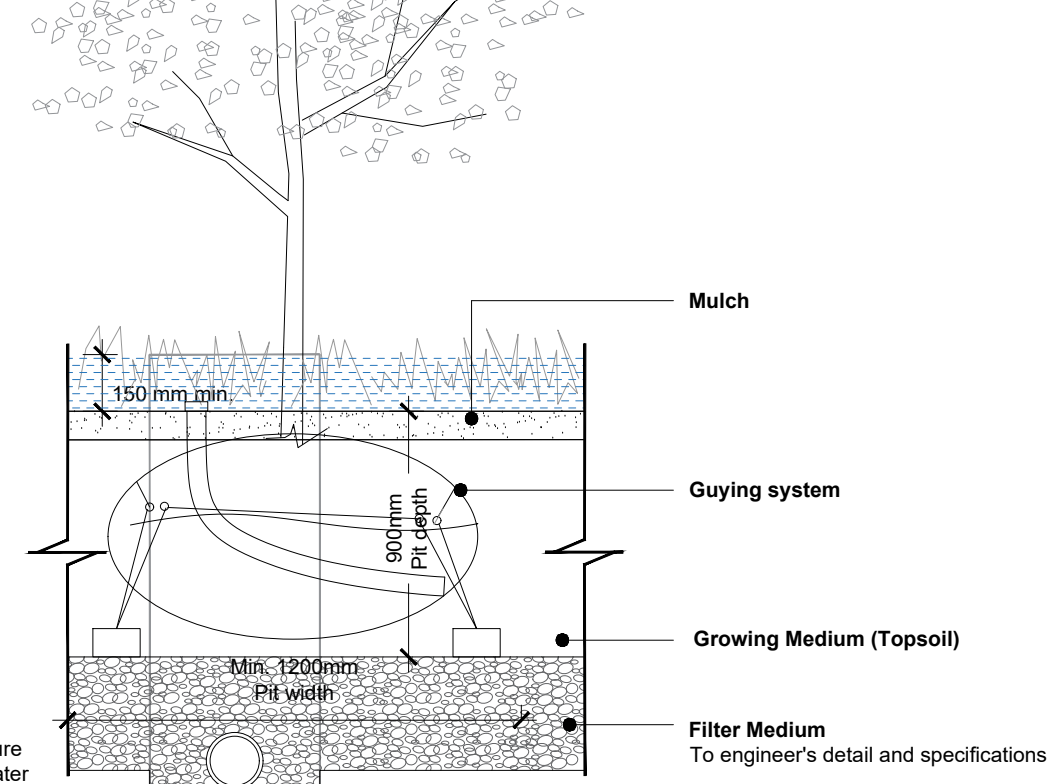

**BIORETENTION AREA**

12  
2500

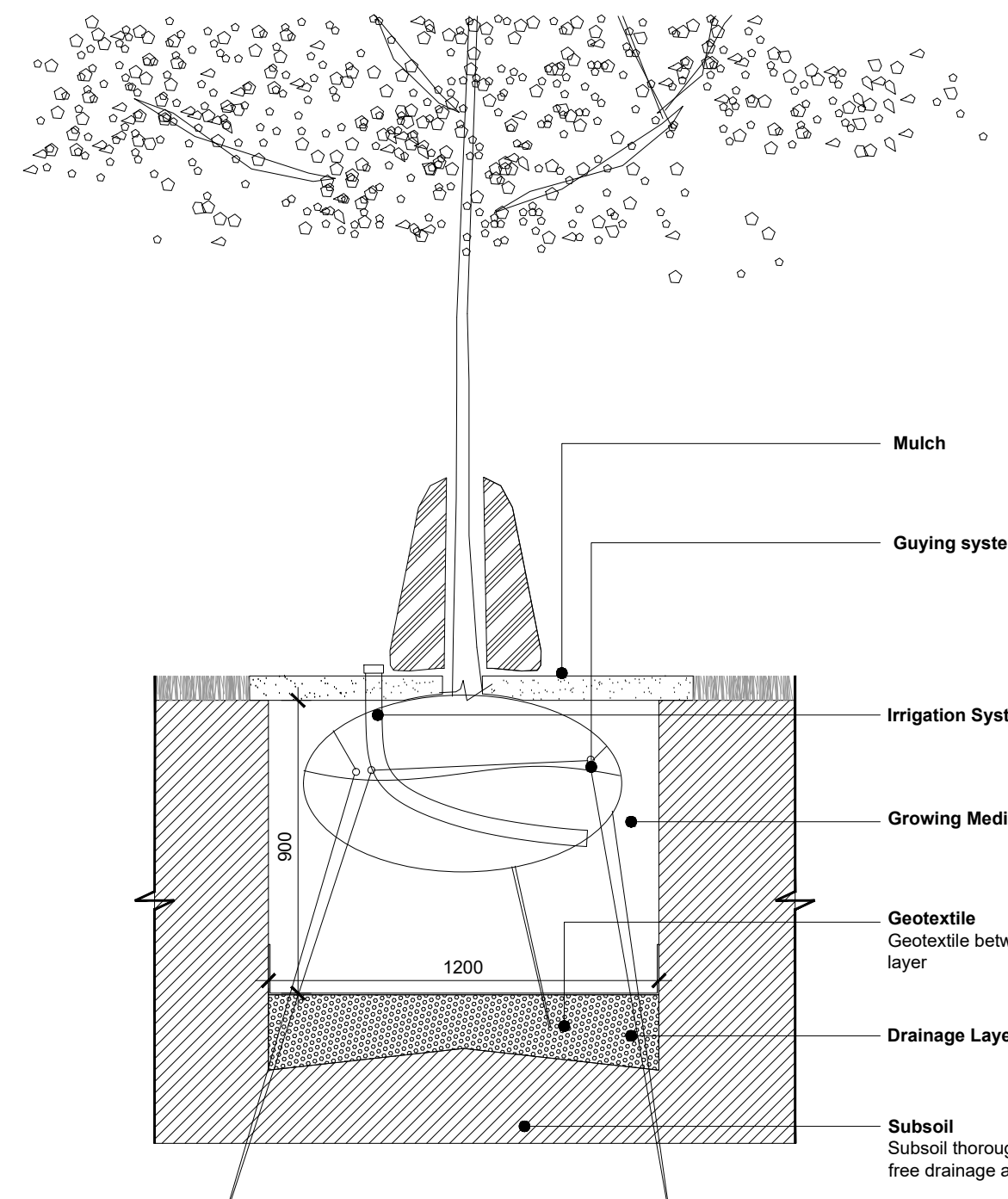

**TREE PLANTING IN SOFT LANDSCAPE**

13  
2500

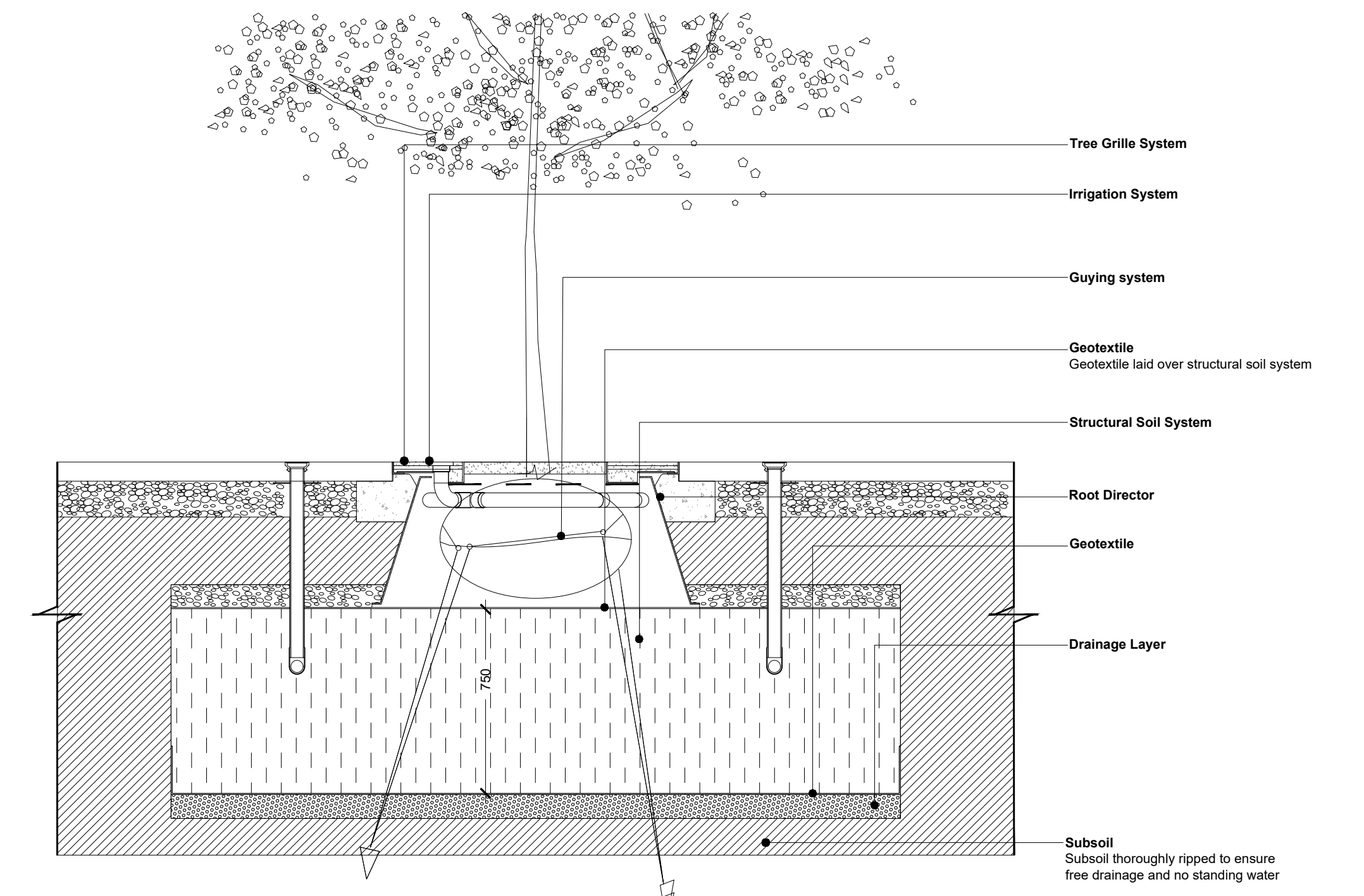

**TREE PLANTING IN HARD LANDSCAPE**

14  
2500

This drawing is the copyright of the Landscape Architect. Unless otherwise stated all dimensions are in millimetres. Where dimensions are not given, drawings must not be scaled and the matter must be referred to the Landscape Architect. If the drawing includes conflicting details/dimensions the matter must be referred to the Landscape Architect. All dimensions must be checked on site. The Landscape Architect must be informed, by the Contractor, of any discrepancies before public realm improvements proceed.

NOTES:

DATE	REV.	DESCRIPTION	DRAWN BY	CHECKED BY

<b>CLIENT:</b>	FINGAL COUNTY COUNCIL	<b>ISSUE STATUS:</b>	N/A
<b>PROJECT:</b>	PUBLIC REALM IMPROVEMENTS FOR A PEDESTRIANISED NEW STREET	<b>PLANNING:</b>	
<b>DRAWING:</b>	TYPICAL LANDSCAPE DETAILS	<b>DRAWING NO.:</b>	FC.03-DR-2500
<b>PROJECT NO.:</b>	FC.03	<b>SCALE:</b>	1:20
<b>SHEET SIZE:</b>	A1	<b>DRAWN BY:</b>	IK
<b>CHECKED BY:</b>	IC	<b>1st ISSUE:</b>	13.04.2023

**DFLA**  
Landscape Architects